

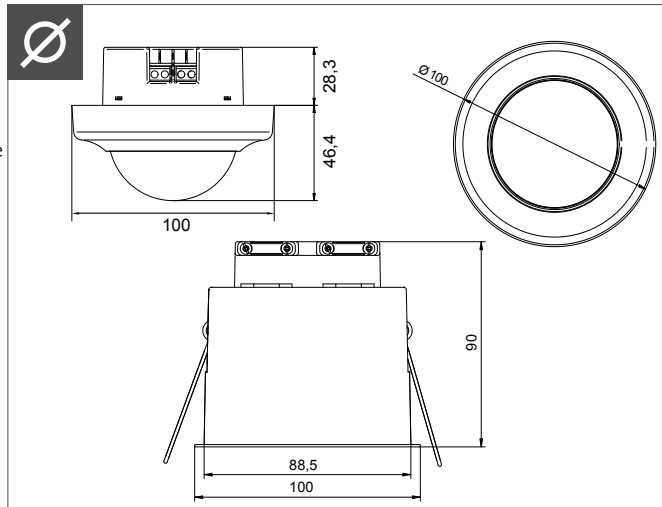

2300 W	1200 VA	μ 10A	IP54	-5°C - +50°C
5 min. - ∞	100-2000 lux	360°	800 m ²	4-8 m

41-760 - 8 m Ceiling

Bevægelsessensor DALI, 4 zoner
 Motion detector DALI, 4 zones
 Bewegungsmelder DALI, 4 Zonen
 Détecteur de mouvement DALI, 4 zone
 Rørelsesensor DALI, 4 zoner
 Bevægelsessensor DALI, 4 soner



+i

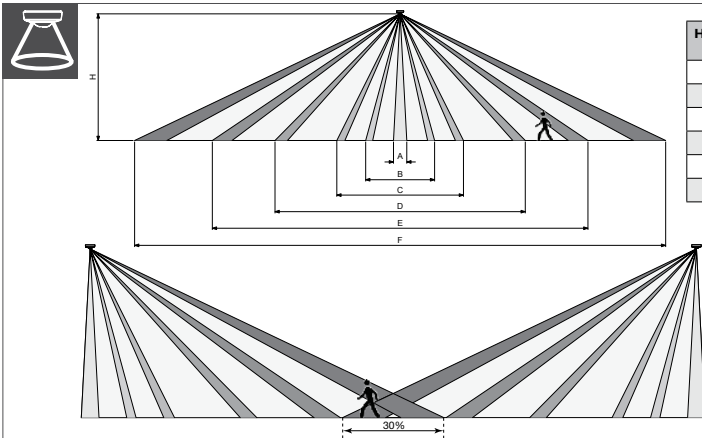

Height (H)	4 m	5 m	6 m	7 m	8 m
A	Ø0,20	Ø0,25	Ø0,30	Ø0,40	Ø0,50
B	Ø2,00	Ø2,50	Ø3,00	Ø3,50	Ø4,00
C	Ø3,70	Ø4,70	Ø5,50	Ø7,00	Ø7,50
D	Ø6,50	Ø8,50	Ø10,00	Ø11,50	Ø14,00
E	Ø11,00	Ø14,00	Ø17,00	Ø20,00	Ø22,00
F	Ø16,00	Ø20,00	Ø24,00	Ø28,00	Ø32,00

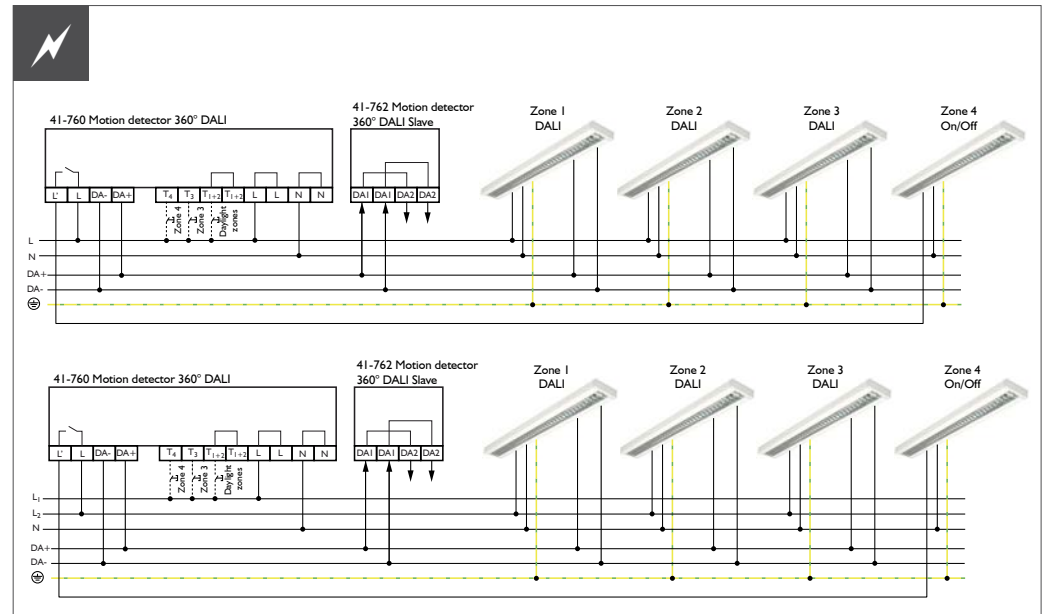
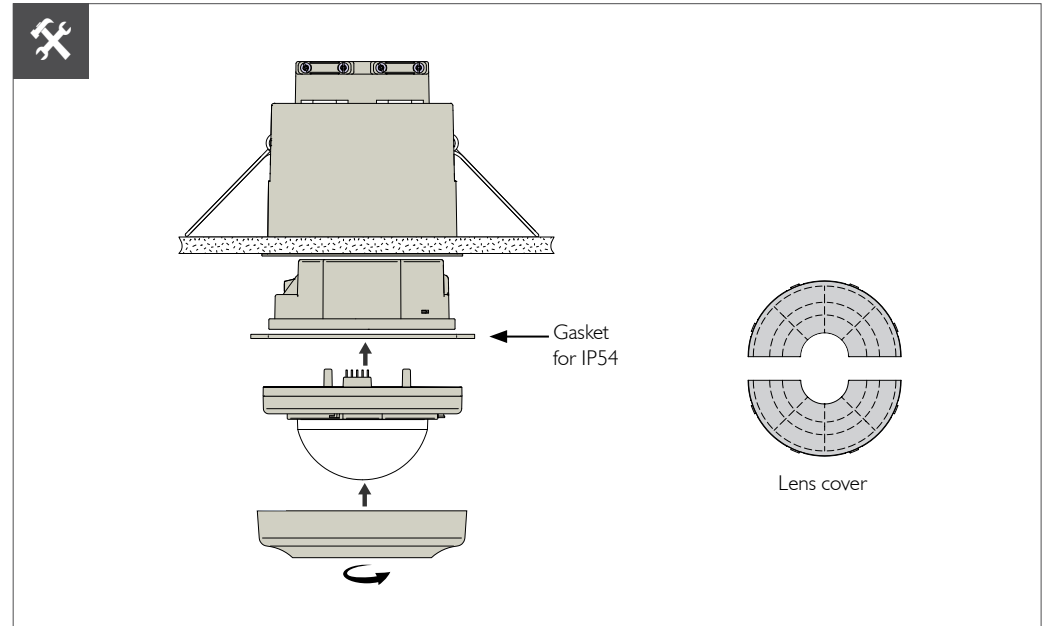

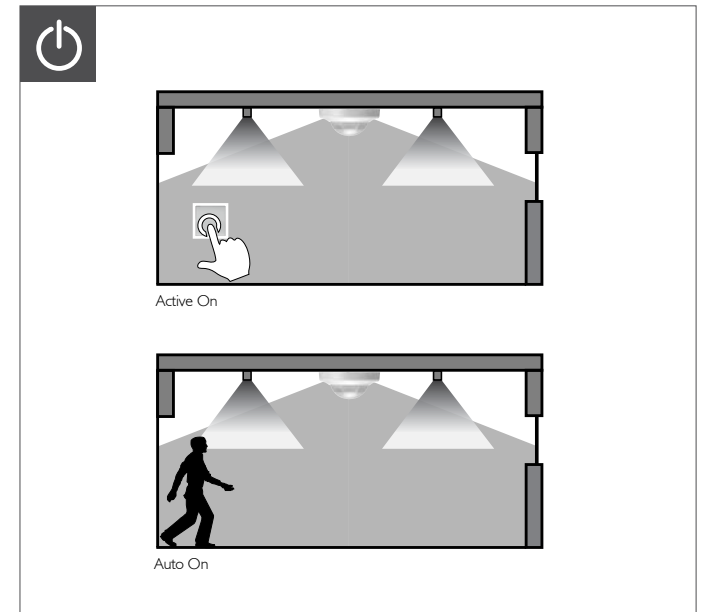
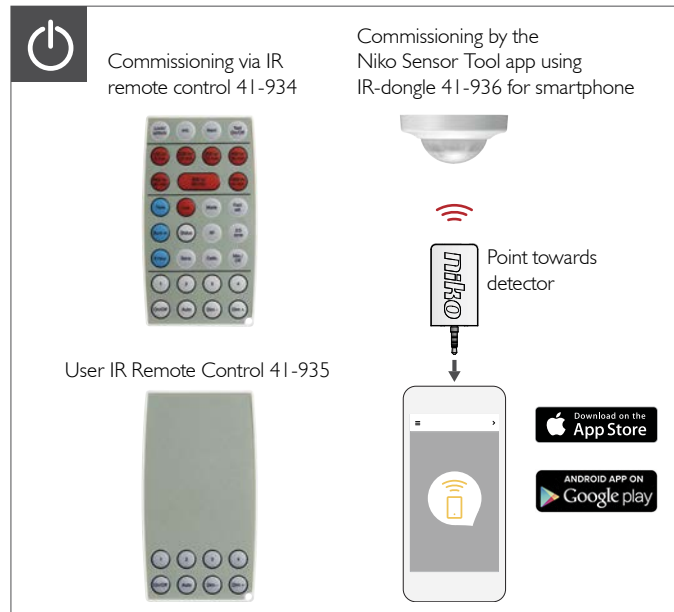
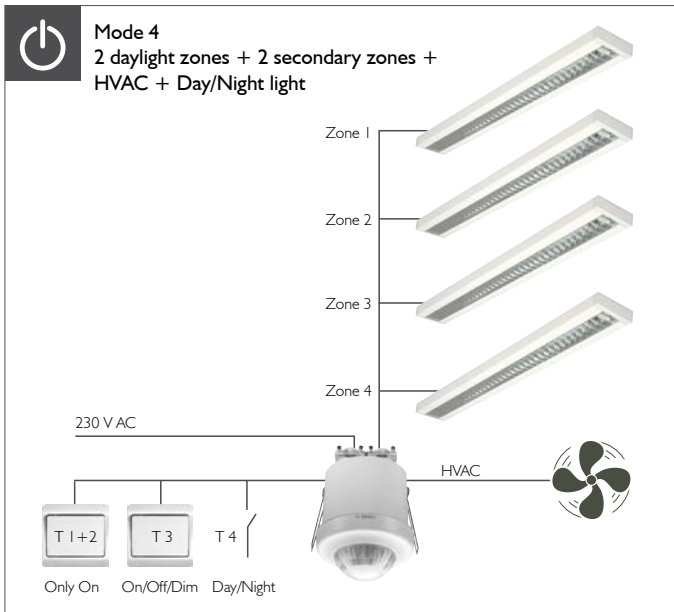
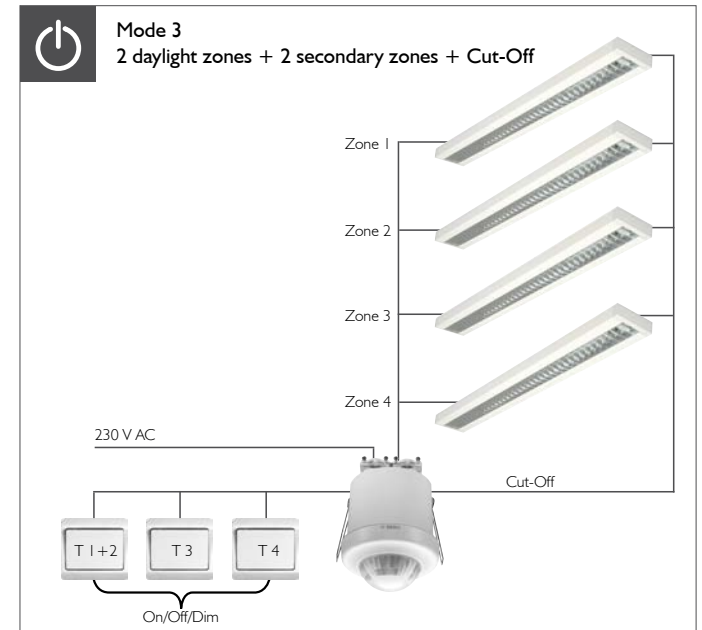
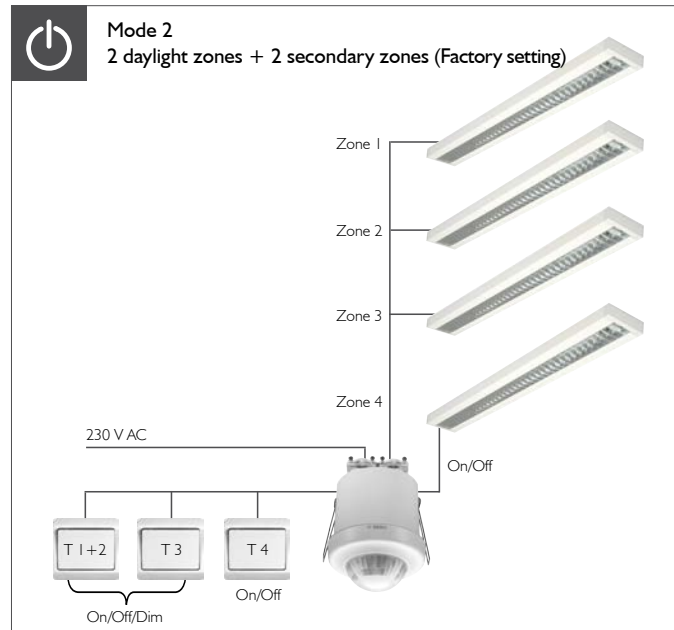
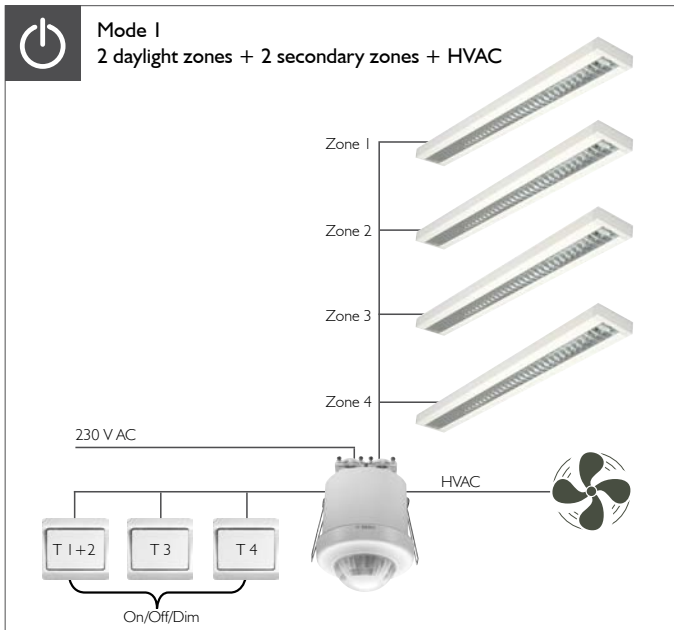



Guideline

The following guideline can be used for quick detector setup:

1. Position the detector.
2. Connect the detector according to the circuit diagram.
The detector is now in the "Out-of-the-box" mode.
3. Test the installation for any errors or missing luminaires.
4. Initialise all DALI devices and divide the luminaires into zones.
Note: Now the detector operates according to factory settings
If this is required - go directly to step 13
For other settings continue with step 5-13
5. Select mode.
6. Program the required function: Automatic On/Off or Active On/Off with automatic off via the detector for the individual zones.
7. Select the number of daylight zones, 2 or 3.
8. Choose whether the daylight zones are to remain at the minimum level or if they are to turn off in case of over illumination.
9. Set the required lux level for the daylight zones.
10. Set the maximum lux output for the lighting system.
See documentation for the lighting system or measure with a lux meter.
11. Set times.
12. The detector makes a fine-calibration of the lux-setting based on the room reflectance, when the lux level is 100 lux and nobody is in the room (typically at night). It may in certain cases be necessary to fine tune using a lux meter. This can only be performed after the detector has performed fine-calibration.
13. Enable a "Burn-in". Applies to fluorescent tube lights only.



Factory settings

App.:	Mode 2 - Daylight control and relay output for light On/Off.
Function:	Automatic On/Off via detector
Zones:	2 daylight and 2 secondary zones
Lux:	300 lux
Time 1 (Off delay):	15 minutes
Time 2 (HVAC):	30 minutes
Time 3 (Cut-Off):	60 minutes
Time 4 (Orientation light):	10 minutes
Min/Off:	Minimum - Daylight zones remain at minimum level in case of over-illumination.
Sensitivity:	High sensitivity - All sectors



Initialization/Zone selection

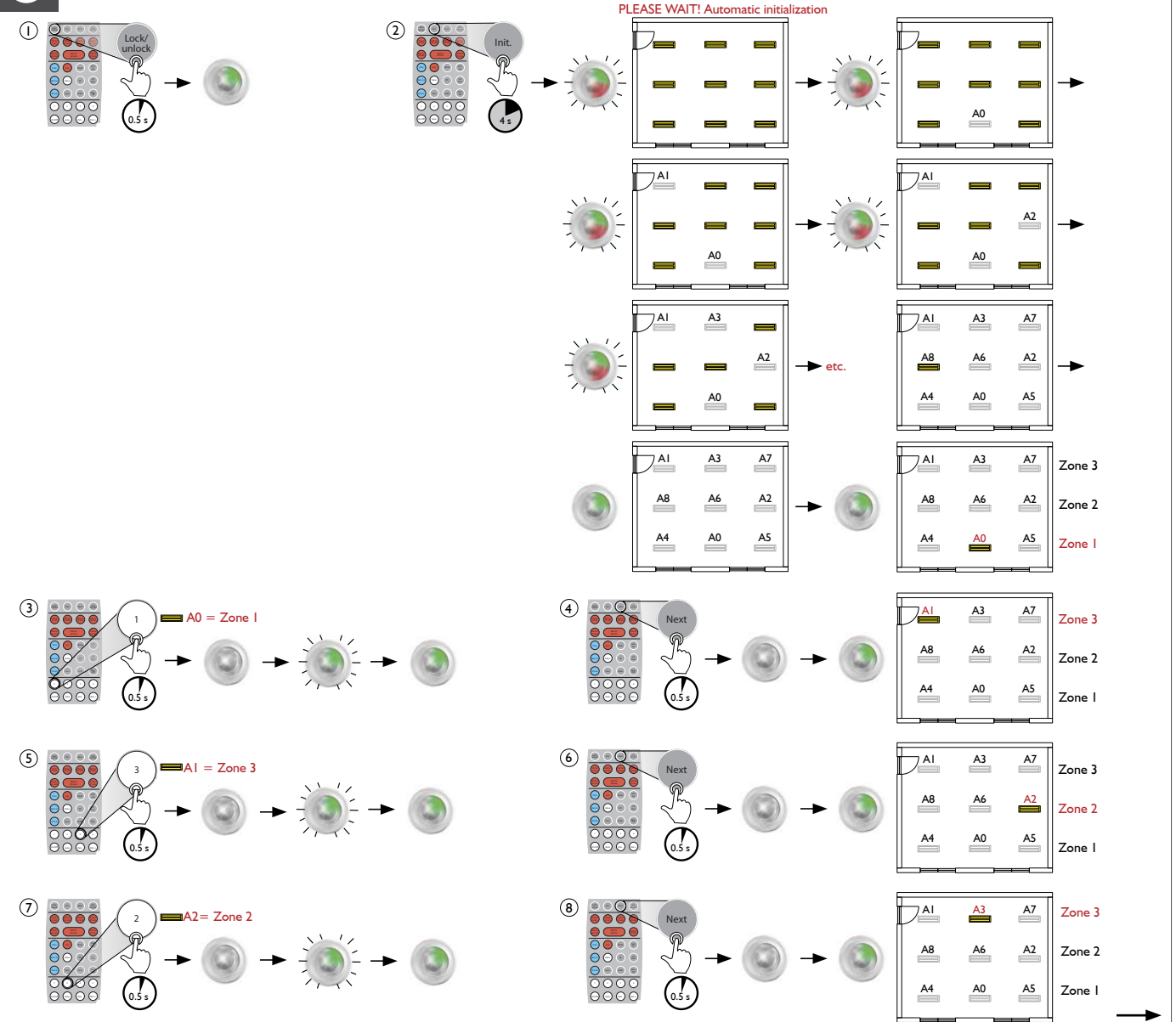

Initialization/Zone selection

9 Press 3 for 0.5 s → A3 = Zone 3 → ect.

10 Press Next for 0.5 s →

A1	A3	A7	Zone 3
A8	A6	A2	Zone 2
A4	A0	A5	Zone 1

11 Press 2 for 0.5 s → A8 = Zone 2

12 Press Next for 0.5 s → A0..A8 = Done

13 Press Lock/unlock for 0.5 s → Please note!
Detector will start daylight calibration cycle as soon as light conditions allow it!

Mode 1
Daylight control with HVAC output

1 Press Lock/unlock for 0.5 s

2 Press Mode for 0.5 s

3 Press 1 for 0.5 s

4 Press Lock/unlock for 0.5 s

Mode 2
Daylight control with relay for lighting (On/Off)

1 Press Lock/unlock for 0.5 s

2 Press Mode for 0.5 s

3 Press 2 for 0.5 s

4 Press Lock/unlock for 0.5 s

Mode 3
Daylight control with relay for cut-off

1 Press Lock/unlock for 0.5 s

2 Press Mode for 0.5 s

3 Press 3 for 0.5 s

4 Press Lock/unlock for 0.5 s

Mode 4
Daylight control with Day/Night light

1 Press Lock/unlock for 0.5 s

2 Press Mode for 0.5 s

3 Press 4 for 0.5 s

4 Press Lock/unlock for 0.5 s

Select between Auto On or Active On (daylight zones)

① Lock/unlock (0.5 s)

②A On/Off (0.5 s) → Active On

OR

②B On/Off (0.5 s) → Auto On

③ Lock/unlock (0.5 s)

Select 2 or 3 daylight zones

① Lock/unlock (0.5 s)

②A 2/3 zone (0.5 s) → 3 Zones

OR

②B 2/3 zone (0.5 s) → 2 Zones

③ Lock/unlock (0.5 s)

Select Minimum or Off, daylight zones

① Lock/unlock (0.5 s)

②A Min/Off (0.5 s) → Off

OR

②B Min/Off (0.5 s) → Minimum

③ Lock/unlock (0.5 s)

Required lux level and max output, luminaires (See also - Max lux output, luminaires)

① Lock/unlock (0.5 s)

② Lux (0.5 s)

③ 200 lx / 10 min (0.5 s)

④ Lock/unlock (0.5 s)

Max lux output, luminaires (Required lux level and max output, luminaires - must be done first)

① Lock/unlock (0.5 s)

② Lux (4 s)

③ 400 lx / 30 min (0.5 s)

④ Lock/unlock (0.5 s)

Time 1 - Off delay timer

- 1 Lock/unlock (0.5 s)
- 2 Time (0.5 s)
- 3 1 = Off delay timer (0.5 s)
- 4 300 lx / 15 min e.g. 15 min (0.5 s)
- 5 Lock/unlock (0.5 s)

Time 2 - HVAC timer

- 1 Lock/unlock (0.5 s)
- 2 Time (0.5 s)
- 3 2 = HVAC timer (0.5 s)
- 4 400 lx / 30 min e.g. 30 min (0.5 s)
- 5 Lock/unlock (0.5 s)

Time 3 - Cut-off timer

- 1 Lock/unlock (0.5 s)
- 2 Time (0.5 s)
- 3 3 = Cut-Off timer (0.5 s)
- 4 800 lx / 60 min e.g. 60 min (0.5 s)
- 5 Lock/unlock (0.5 s)

Time 4 - Orientation light timer

- 1 Lock/unlock (0.5 s)
- 2 Time (0.5 s)
- 3 4 = Orientation light timer (0.5 s)
- 4A 200 lx / 10 min e.g. 10 min (0.5 s) OR 4B On/Off e.g. Off (0.5 s)
- 5 Lock/unlock (0.5 s)

Enable burn-in

1. Press **Lock/unlock** (0.5 s)
2. Press **Burn in** (0.5 s)
3. Press **Lock/unlock** (0.5 s). **100 hours Burn-in is in operation**

Miljø: Dette produkt og / eller de medfølgende batterier må ikke deponeres i ikke-genanvendeligt affald. Det kasserede produkt skal afleveres til en genbrugsstation. Din rolle er lige så vigtig som producentens og importørens med hensyn til at fremme sortering, genanvendelse og genbrug af kasseret elektrisk og elektronisk udstyr. For at finansiere affaldssamlingen og affaldsbehandlingen opkræver regeringen i nogen tilfælde genbrugsafgifter (prisen på dette produkt er inklusiv disse afgifter).

Environment: This product and/or the batteries provided cannot be deposited in non-recyclable waste. Take your discarded product to a recognised collection point. Just like producers and importers, you too play an important role in the promotion of sorting, recycling and reuse of discarded electrical and electronic equipment. To finance the rubbish collection and waste treatment, the government levies recycling charges in certain cases (included in the price of this product).

Umwelt: Sie dürfen dieses Produkt oder die mitgelieferten Batterien nicht über den normalen Hausmüll entsorgen. Bringen Sie Ihr ausgedientes Produkt zu einer anerkannten Sammelstelle. Genau wie Hersteller und Importeure spielen auch Sie eine wichtige Rolle bei Sortierung, Recycling und Wiederverwendung von ausgedienten elektrischen und elektronischen Geräten. Um die Abholung und Verarbeitung wiederverwertbarer Abfälle finanzieren zu können, ist im Verkaufspreis oftmals bereits eine obligatorische Recyclingabgabe enthalten.

Environnement: Vous ne pouvez pas mettre ce produit ou les batteries fournies au rebut en tant que déchet non trié. Déposez votre produit usagé à un point de collecte agréé. Tout comme les fabricants et importateurs, vous jouez un rôle important dans la promotion du tri, du recyclage et de la réutilisation d'appareils électriques et électroniques mis au rebut. Pour financer la collecte et le traitement, les pouvoirs publics ont prévu, dans certains cas, une cotisation de recyclage (comprise dans le prix d'achat de ce produit).

Omgivelser: Dette produktet og / eller de tilhørende batteriene skal kastes sammen med ikke-resirkulerbart affald. Ta med det kasserte produktet til en godkjent henteplass. På samme måte som produsenter og importører, spiller du også en viktig rolle med å fremme sortering, resirkulering og gjenbruk av kassert elektrisk og elektronisk utstyr. For å finansiere bortkjøring av avfall og avfallsbehandling, kan staten legge en resirkuleringsavgift i visse tilfeller (inkludert i prisen til dette produktet).

Miljö: Denna produkt och/eller de medföljande batterierna får inte slängas bland icke-återvinningsbart avfall. Ta med din kasserade produkt till ett godkänt insamlingsställe. Precis som tillverkare och importörer spelar du också en viktig roll i arbetet för sortering, återvinning och återanvändning av kasserad elektrisk och elektronisk utrustning. För att finansiera avfallshämtning och avfallshantering tar myndigheterna i vissa fall ut avgifter (ingår i priset på produkten).

EMBALLAGES
CARTONS ET PAPIER
À TRIER

+i

For further information about programming, status and operation - Scan QR code or see www.niko.dk/produkt/41-760.

!

Advarsel: Indbygning og montering af elektriske apparater må kun foretages af aut. elinstallatør. Ved fejl eller driftforstyrrelser kontakt den aut. elinstallatør. Ret til ændringer forbeholdes!

Warning: Installation and assembly of electrical equipment must be carried out by qualified electricians. Contact a qualified electrician in case of fault or breakdown. Reserving the right to make changes!

Warnung: Einbau und Montage elektrischer Geräte dürfen nur durch Elektrofachkräfte erfolgen. Wenden Sie sich bei Störungen bzw. Ausfall an einen Elektrofach-kraft. Änderungen vorbehalten !

Avertissement: L'installation et le montage d'appareils électriques doivent exclusivement être exécutés par un électricien agréé. En cas de défaut ou de perturbation du fonctionnement, contacter un installateur électricien agréé. Sous réserve de modifications!

Warning: Elektriska apparater får endast byggas in och monteras av en auktoriserad elinstallatör. Kontakta den auktoriserade elinstallatören vid fel eller driftstörningar. Med reservation för ändringar!

Advarsel: Innbygging og montering av elektriske apparater må kun utføres av autorisert elektriker. Autorisert elektriker skal også kontaktes ved feil eller driftsforstyrrelser. Det tas forbehold om endringer.