

LIQMAX III

ARGB VERSION



ELC-LMT120-ARGB



- ▶ **Patented Dual Chamber water block design**
- ▶ **Patented Shunt Channel Technology**
- ▶ **The luminous addressable RGB fan and Aurabelt™ water block display gorgeous lighting effects with 16.8 million colors**
- ▶ **Exclusive dual-convex blade can create high-volume air flow (72.1 CFM)**



LIQMAX III ARGB, an addressable RGB AIO cooler for Intel® and AMD® CPU platforms, is designed to sync with ASUS Aura Sync, GIGABYTE RGB Fusion, MSI Mystic Light Sync and ASRock Polychrome to display 16.8 million colors and dynamic lighting effects. The Patented Dual Chamber Design water block has a Central Coolant Inlet (CCI) structure, combined with the Shunt-Channel Technology (SCT) on the cold plate, it is able to inject the coolant at the hottest spot to prevent heat surges and shorten the coolant flow path, resulting in faster heat transfer. In addition, the dual-convex blade is able to generate air pressure and high-volume air flow to provide optimal cooling performance. LIQMAX III ARGB cooler is an ideal choice for mainstream water-cooler addressable RGB gaming rigs.

Features

- ▶ **Patented Dual-Chamber Design water block**
Patented Dual-Chamber Design isolates the pump from the heat to prolong the cooler's lifetime

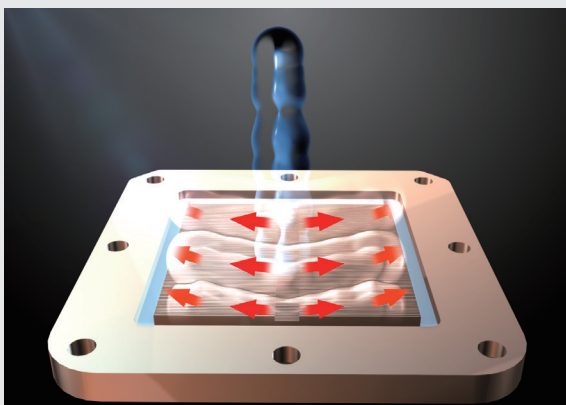
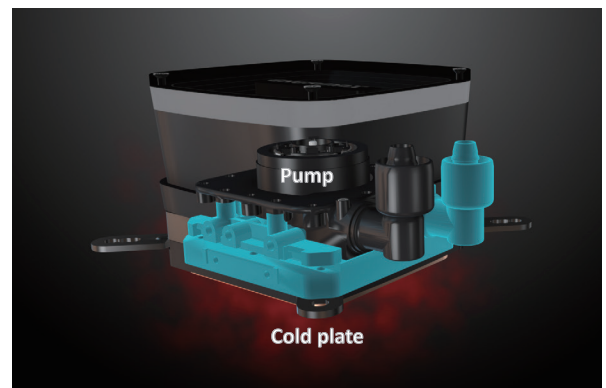

- ▶ **Central Coolant Inlet (CCI) design and patented Shunt-Channel Technology (SCT)**

Patented Dual Chamber Design water block has a Central Coolant Inlet (CCI) structure, combined with the Shunt-Channel Technology (SCT) on the cold plate, it is able to inject the coolant at the hottest spot to prevent heat surges and shorten the coolant flow path, resulting in faster heat transfer

▀ The luminous addressable RGB fan and Aurabelt™ water block display gorgeous lighting effects with 16.8 million colors



▀ Addressable RGB lighting synchronization

LIQMAX III ARGB is designed to synchronize with motherboards featuring an addressable RGB header (3 pin assignment is 5V/D/G). User can program preferred lighting effects via motherboard software.

▀ Exclusive dual-convex blades

Exclusive dual-convex blade fan creates down force air pressure (max. 1.98mmH₂O) and high-volume air flow (max. 72.1CFM).

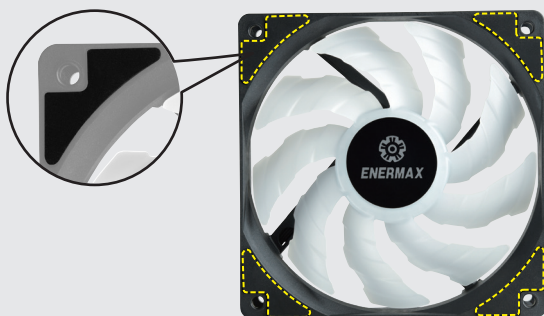
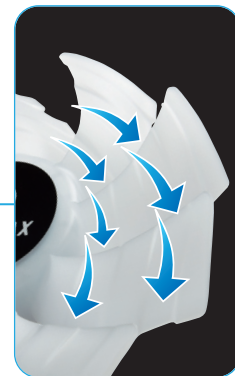
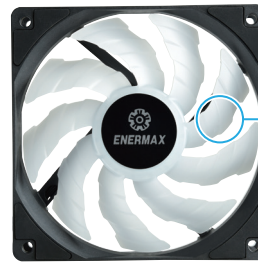

▀ Anti-vibration rubber pads minimize noise during operation

▀ Premium 400mm weaved tubing is perfect for mainstream system builds



Dimensions

unit:mm

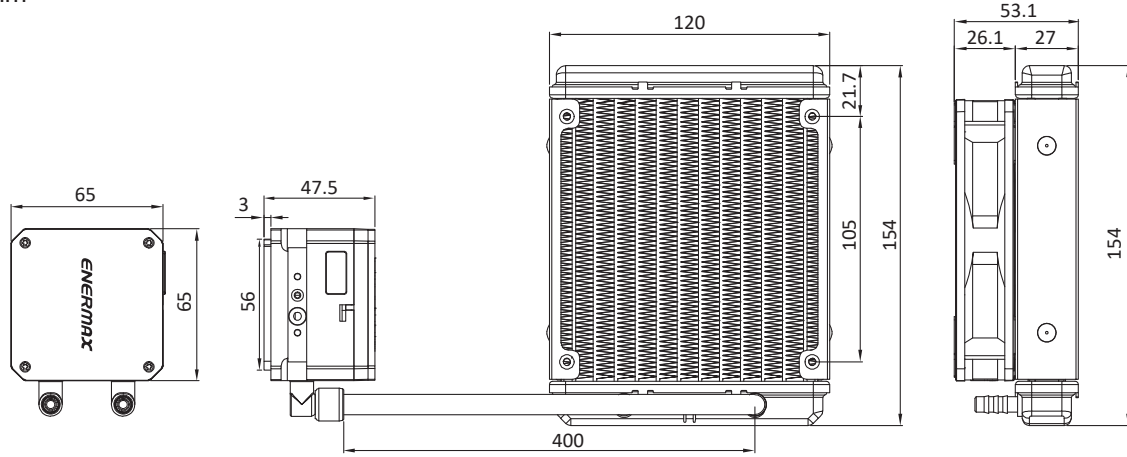

Specifications

Model Number		ELC-LMT120-ARGB
CPU Socket		Intel® LGA 1700/1200/115x/2066/2011/2011-3/1366 AMD®AM5/AM4/AM3+/FM2+/FM1
Material		Copper Base with Aluminum Radiator
Pump	Bearing	Ceramic Bearing
	MTBF	50,000 hrs
	Motor Speed	3100 RPM ± 10%
	Rated Voltage	12 V
Water Block	Rated Current - Pump	0.4A [or 0.53A if not connected to 3 pin ARGB connector (5V/D/-/G)]
	Rated Current - RGB LED	0.18 A
Tube	Material	Rubber
	Length	400 mm
Weight (W/O fan)		690 g
Fan	Dimension	120 x 120 x 25 mm
	MTTF	50,000 hrs
	Speed	500~1600 RPM
	Rated Voltage	12 V
	Rated Current - Fan	0.17 A
	Rated Voltage - RGB LED	5 V
	Rated Current - RGB LED	0.36 A
	Air Flow	22.5~72.1 CFM
	Static Pressure	0.2~1.98 mm-H2O
	Noise Level	14~27 dBA
Connector		4 pin PWM connector 3 pin ARGB connector (5V/D/-/G)
Thermal Grease		Dow Corning® TC-5121C
Shipping information		
Barcode	EAN	4713157724267
	UPC	819315024263
Box Dimension		254 x 215 x 137 mm
Gross Weight / unit		1.41 kg
Carton Dimension		539 x 300 x 460 mm
Q'ty / carton		8 pcs
Gross Weight / Carton		12.546 kg

Note: An addressable RGB mainboard with 5V header is needed to provide full lighting capability. In stand-alone mode, only the water block is illuminated with the Racing-Rainbow effect.